

## | Washer Dryer

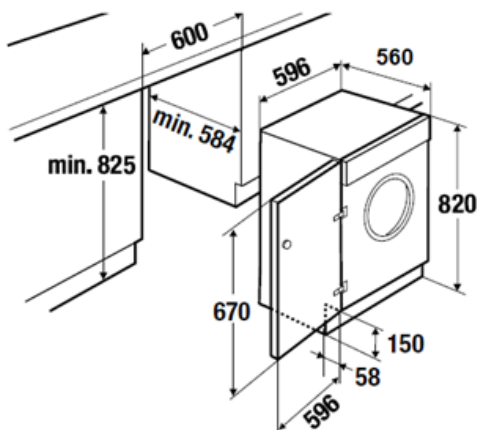

**WT 6800.0i**  
**Built-in Washer Dryer**



<b>Product Features</b>	<ul style="list-style-type: none"> <li>Control panel with symbols and digital display</li> <li>LED program sequence indicator</li> <li>Electronic delay start timer with remaining time display</li> <li>Fully electronic</li> <li>Acoustic signal at end of program</li> <li>15min fast washing program</li> <li>5 washing temperature</li> <li>Appliance door hinge on the left</li> <li>Reversible door hinges</li> <li>Lint filter in the plinth</li> </ul>
<b>Technical Information</b>	<ul style="list-style-type: none"> <li>Washing capacity: 7kg</li> <li>Drying capacity: 4kg</li> <li>Spin speed: 1400/1200/1000/800/600</li> <li>15 programs (12 washing + 3 drying)</li> <li>Electrical connection: 2.2kW</li> <li>Energy consumption: 0.83kWh/cycle</li> <li>Water consumption: 52L</li> </ul>
<b>Dimensions (H x W x D)(mm)</b>	<ul style="list-style-type: none"> <li>Approx.: 820 x 596 x 560</li> <li>Niche: approx. 825 x 600 x 575</li> </ul>
<b>Energy Efficiency</b>	<ul style="list-style-type: none"> <li>Energy efficiency: Grade 4</li> <li>Water efficiency: Grade 1</li> </ul>
<b>Country of origin</b>	<ul style="list-style-type: none"> <li>Italy</li> </ul>

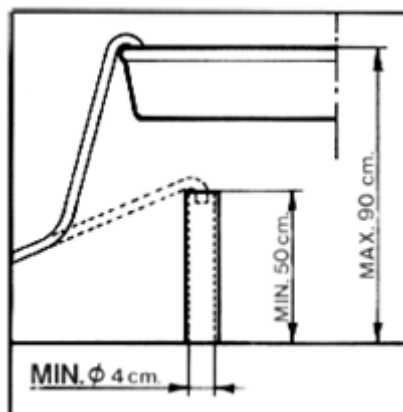

**SHUN HING ELECTRIC WORKS AND ENGINEERING CO., LTD.**

Office: 9/F, Peninsula Centre, 67 Mody Road, Tsim Sha Tsui East, Kowloon, Hong Kong

Tel: (852) 2861 2767 Website: <http://teka.shew.com.hk/zh>

- Photos are for reference only
- Specification and technical information are subject to change without prior notice.

**Customer Service & Experience Centre**

Office: 9/F, Peninsula Centre, 67 Mody Road,

Tsim Sha Tsui East, Kowloon, Hong Kong

Tel: (852) 2313 0666

- Right of technical modification reserved.
- The actual color and sizes may vary slightly.



**SHUN HING GROUP**  
信興集團  
SINCE 1953