

Instructions for use

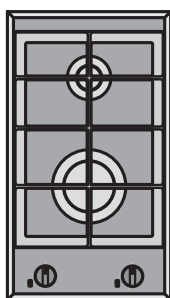

Gas hobs for installation in worktops



GKS 3920.0

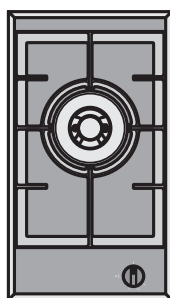

GWS 3911.0

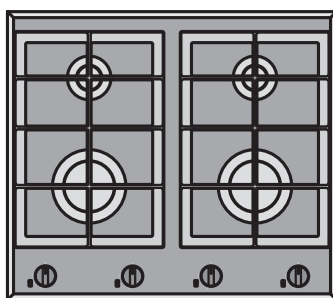

GKS 6940.0

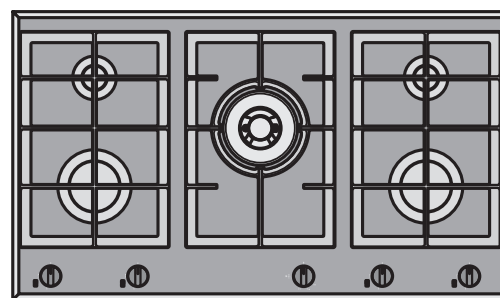

GKS 9951.0

For use in: Hong Kong
Issue: 2014-01-14
Version: 1.3_EN
Identity no.: 073587_HK

Küppersbusch

FÜR KÜCHEN MIT STIL

Dear customer,

We thank you for your confidence in our product. We are supplying you with a high-quality Küppersbusch product. As part of quality controls conducted prior to its delivery, it was inspected to ensure that it is in its proper condition.

For the purpose of safe, appropriate use, please read the instructions for use and other documentation accompanying the product carefully and store them until the product is disposed of. Please inform us should faults become apparent or information be missing (address, see last page).

The instructions for use are protected by copyright and intended exclusively for users of the appliance.

Contents

1	Safety and responsibility	6
1.1	Appropriate use.....	6
1.2	User responsibility.....	6
1.3	Qualification of persons	7
1.4	Warnings in these instructions for use	7
2	Overview of the gas hobs	8
2.1	Gas hob GKS 3920.0.....	8
2.2	Gas hob GWS 3911.0	8
2.3	Gas hob GKS 6940.0.....	9
2.4	Gas hob GKS 9951.0.....	9
3	Installation and operation	10
3.1	Installation and operation safety	10
3.2	Gas hob installation	11
3.2.1	Making a hole in the worktop	11
3.2.2	Installing several gas hobs	12
3.2.3	Mounting clips for fastening the gas hobs	12
3.2.4	Installing the gas hob.....	13
3.3	Connecting the gas hob.....	13
3.4	Operation	14
4	Cleaning	16
5	Troubleshooting	17
5.1	Safety when troubleshooting.....	17
5.2	Finding faults.....	18
6	Technical data	19

7	Changing types of gas.....	20
7.1	Injector specification	20
7.2	Changing gas used by high-capacity and standard burners.....	21
7.3	Changing the gas used by the WOK burner	25

1 Safety and responsibility



For the purpose of safe, appropriate use, please observe the safety instructions before you use the appliance.

1.1 Appropriate use

The appliance is intended to be used exclusively for preparing food in the home. According to the EN 30 standards, the gas hobs belong to appliance category 3: "Appliances for Installation in Kitchen Units or Worktops".

The appliances may only be operated when they have been adapted to the local gas supply - see the marking on the back of the appliance - and when the instructions for use are available in the language of the respective country. The instructions for use are a component of the appliance and must be handed over when it is passed on or sold.

Any other possible fields of application or uses, and modifications, attachments or alterations may considerably jeopardise the safety, reliability and functioning of the appliance. Such measures rule out any Küppersbusch guarantee, and responsibility for personal injury and damage to property is passed on to the user.

1.2 User responsibility

The user is responsible for the safe, appropriate operation of the appliance.

This includes:

- A supply of energy and spatial requirements (space needed, ventilation, room air conditions, etc.).
- Children must be under permanent supervision when the appliance is operating in order to ensure that they do not play with the appliance.
- The appliance must be installed in accordance with local regulations.
- Regular inspections are to be carried out by a professional gas fitter.
- It is recommended that you conclude a maintenance agreement in order to ensure long-term, failure-free operation.
- Legibility and completeness of the instructions for use at the place of use.
- Rectification of faults when relevant measures are described in these instructions for use. Make contact with the dealer for other measures.
- Legibility and completeness of all the safety signs and nameplates on the appliances.
- When an appliance is finally put out of operation: careful separation of electronic and metal components and disposal or recycling in accordance with legal provisions.



1.3 Qualification of persons

Persons performing operations on the appliance during its individual life phases must be appropriately qualified.

Operations	Person	Qualification
Erection, installation	User	Knowledge of these instructions for use
Installation of gas connections, initial operation, maintenance, fault rectification, repairs	Electrician (electrical connections), fitter (gas connections)	Knowledge of specifications for electrical connections or gas connections
Operation, cleaning, fault rectification (provided permitted by the user, see Section 5.2 "Troubleshooting")	User	Knowledge of these instructions for use
Disposal	User	Knowledge of regional specifications, if necessary enquiries at local waste disposal enterprises

1.4 Warnings in these instructions for use

The following safety alert symbols and signal words are used to distinguish potential hazards in these instructions for use.

Safety alert symbol and signal word	Meaning	
 DANGER	Injury to persons	Indication of a dangerous situation which, if not avoided, will result in serious injury or death.
 WARNING		Indication of a dangerous situation which, if not avoided, may possibly result in serious injury or death.
 CAUTION		Indication of a dangerous situation which, if not avoided, may possibly result in medium or minor injury.
IMPORTANT	Damage to property	Indication of a situation which, if not avoided, may result in damage to the appliance or to property in its environment.

2 Overview of the gas hobs

This section contains an overview of the gas hobs and their control elements.

2.1 Gas hob GKS 3920.0

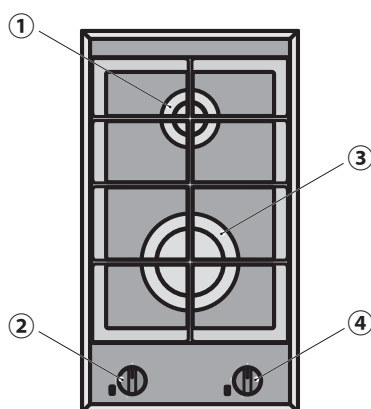

① Standard burner

② Standard burner control knob

③ High-power burner

④ High-power burner control knob

2.2 Gas hob GWS 3911.0

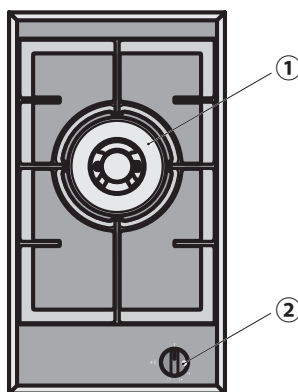

① WOK burner

② WOK burner control knob

2.3 Gas hob GKS 6940.0

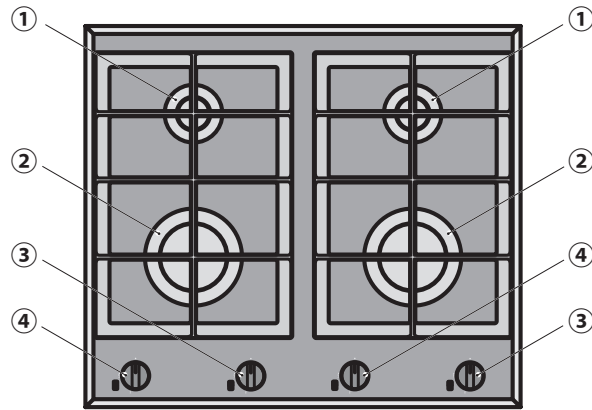

- ① Standard burner
- ② High-power burner
- ③ High-power burner control knob
- ④ Standard burner control knob

2.4 Gas hob GKS 9951.0

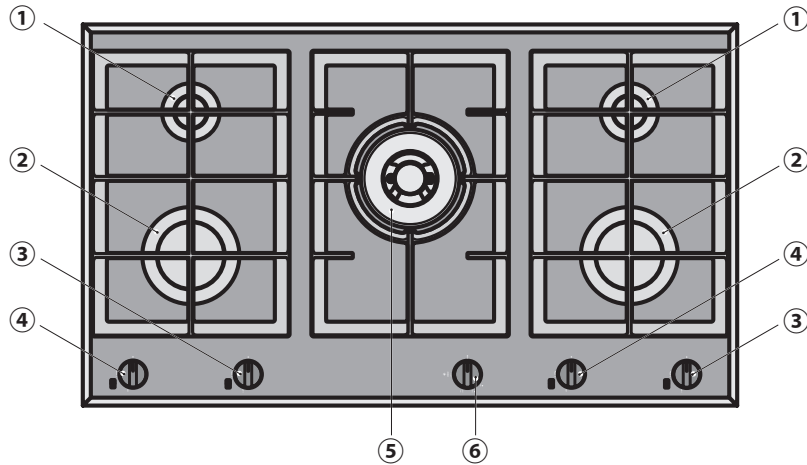

- ① Standard burner
- ② High-power burner
- ③ High-power burner control knob
- ④ Standard burner control knob
- ⑤ WOK burner
- ⑥ WOK burner control knob

3 Installation and operation

3.1 Installation and operation safety



WARNING

Fatal injury caused by explosive gas

- Gas connections must all be installed by a professional gas fitter.
- Only operate gas hobs in a well-ventilated, sufficiently large room (at least 20 m³) or install a mechanical ventilation device, e.g. a cooker hood. Take account of ventilation when making constructional changes to buildings.

Fatal injury caused by fire

- Never install gas hobs near flammable items, e.g. decorations.
- Use heat-resistant wall connection strips which do not rest more than 30 mm on the worktop.
- For combustible installation walls:
 - Minimum clearance at the back: 50 mm (wall made of heat-resistant material, no sockets, no wood, no plastic materials, etc.)
 - Minimum clearance on the left and right: 50 mm
 - Minimum clearance to cooker hoods or wall units installed above the hobs: 650 mm

Fatal injury caused by electricity

- Cables may not come into contact with hot parts.
- Do not bend cables or install them direct on sharp edges.
- Check electrical connections, see Section 6 "Technical data".

Serious burns caused by fat explosions

- Never extinguish burning fat with water; use an extinguisher blanket or foam extinguisher. Overheated fats and oils may spontaneously ignite. Appliances must never be left unattended when in operation.

Serious crushing and knocks

- Danger of slipping: remove fat which has splashed onto the floor immediately.

3.2 Gas hob installation

IMPORTANT Check the delivery note to ensure that the consignment is complete and intact. Do not install a damaged hob; notify the dealer so that your complaint can be processed without any delay.

3.2.1 Making a hole in the worktop

Take account of the space required for the gas connection in the centre underneath the gas hobs.

- Align the worktop with a spirit level.
- Saw out the hole for the gas hobs.
Installation dimensions for the appliance types:

GKS 3920.0 installation dimensions

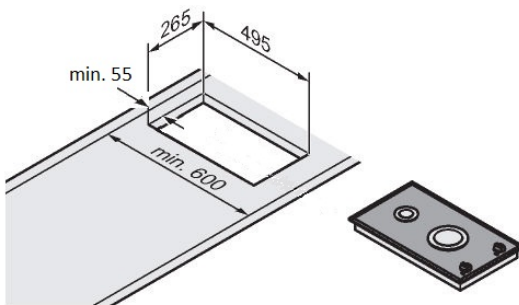

GWS 3911.0 installation dimensions

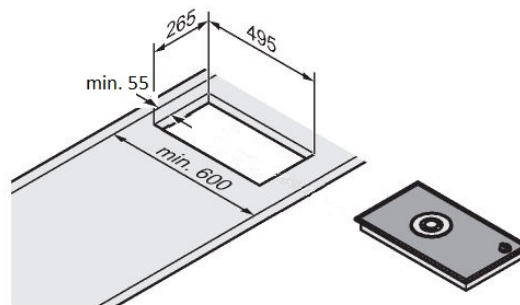

GKS 6940.0 installation dimensions

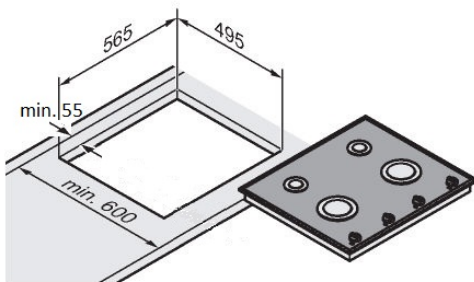

GKS 9951.0 installation dimensions

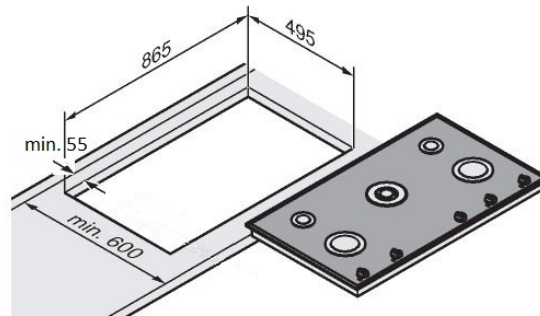

- Seal the cut-out edges with water-resistant varnish.
- Use a heat-resistant, permanently elastic sealant to even out edges and uneven surfaces.

3.2.2 Installing several gas hobs

Take account of the space needed to install several gas hobs:

The worktop may not be narrower than 35 mm between the holes cut out for the gas hobs.

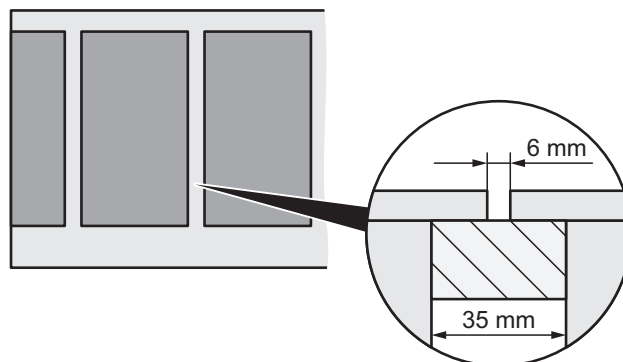

3.2.3 Mounting clips for fastening the gas hobs

Worktop thickness = 30 mm:

→ Screw clips (4 clips) onto the top holders.

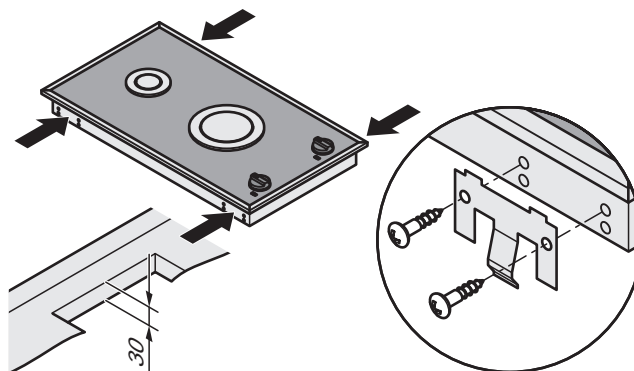

Worktop thickness = 40 mm:

→ Screw clips (4 clips) onto the bottom holders.

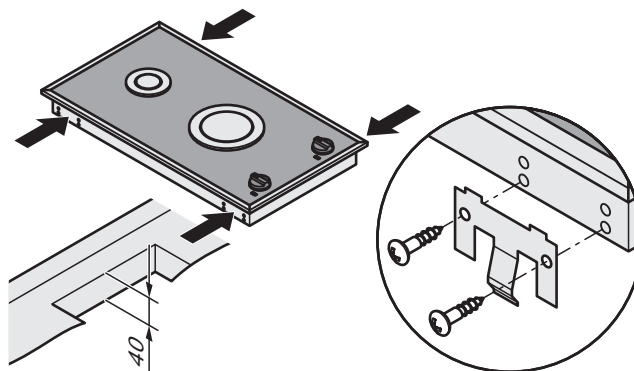

3.2.4 Installing the gas hob

- First of all install the gas hob into the hole at the rear ①, pressing the clips in slightly when doing so ②.
- Install the gas hob into the hole at the front ③, pressing the clips in slightly when doing so ②.
- Check to ensure that the gas hob is flush with the worktop, that it cannot be moved about freely and that the hob sealant has been properly applied.

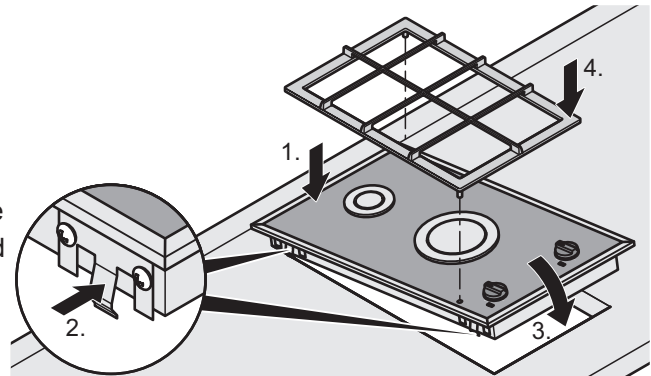

If the gas hob can be moved about freely in the hole, it will be too big. It can be adjusted slightly with the clips.

- Push against the gas hob from below and remove it.
- Bend the clips further outwards.
- Install the gas hob again.
- Install the burner caps.
- Put the saucepan supports in place so that the pins are in the holes ④.

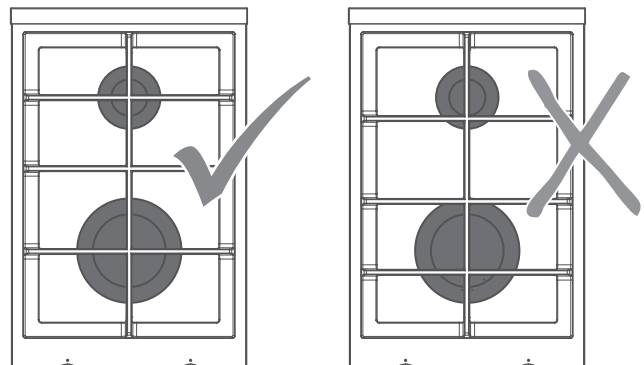

3.3 Connecting the gas hob

- Electrical connection: connect the mains plug of the appliance to a socket with an earthed conductor.
- Gas connection:
 - The gas connection must be made by a professional gas fitter.
 - Observe local gas suppliers' regulations.
 - Observe regulations concerning permissible types of gas; see marking on the back of the appliance.
 - Check the inlet pressure (flow pressure) and flue gas evacuation.
 - Check the gas connection, supplies lines and connections to make sure there are no leaks. The appliance connection may only be checked at a maximum pressure of 150 mbar. Do not operate any valves while carrying out the check.
 - When pipes and hose assemblies are installed it must be ensured that they cannot make contact with the movable parts of the built-in module, e.g. drawers, nor may they be laid through spaces in cupboards which may be filled. The connecting hose may not be subject to tensile or torsional stress, nor may it be crushed or tightly bent. The hose connection may not be pushed onto sharp edges or cutting bodies, it must run freely.

3.4 Operation

The appliance is only intended to be used for cooking food.



WARNING

Fatal injury caused by explosive gas

A smell of gas means that there is a risk of explosion:

- DO NOT ignite gas hobs or electrical switches.
- Immediately close gas shut off valves.
- Open windows and doors.
- Have a gas fitter find out the cause and rectify it.
- If a burner goes off during operation, immediately turn the control knob to position “●” ①.
- Wait at least one minute before re-igniting.
- Never operate the ignition device for longer than 15 seconds.

Fatal injury caused by flue gases

- The use of a gas cooker causes heat, humidity and combustion products to form in the room where the cooker is installed. The room in which the cooker is installed must be well-ventilated, particularly when the cooker is being used. The natural ventilation openings must be kept open or a mechanical ventilation device, e.g. a cooker hood, must be installed.
- Intensive and prolonged use of the appliance may require additional ventilation, e.g. an open window, or effective ventilation, e.g. operation of the mechanical ventilation device at a higher setting.

Fatal injury caused by fire

- Do not allow food to cook until pots and pans are dry.
- Do not switch the burners on if not using them for cooking.
- Only switch the burners on to cook food; do not, for example, use them to heat rooms.
- Keep combustible materials, e.g. plastics, sheeting, sugar and food containing sugar away from hot hobs.
- Make sure connection cables for electrical devices are not jammed on the hot burners.

IMPORTANT

- Never use a glass ceramic hob as a work or storage surface! If the glass ceramic surface shows any signs of cracks, fissures or breakage, switch off the appliance immediately and inform Customer Service (see the last page for the address).
- Do not use any other spacers on the saucepan supports.

Notes on operation:

- Before you cook food for the first time: clean the gas hobs thoroughly.
- Clean the appliance every day.
- Do not use any pots or pans that jut out over the edge of the hob.
Diameter of pots and pans:
 - Standard burner: 12 – 22 cm
 - High-power burner: 22 – 26 cm
 - WOK burner: use only WOK pans
- Set the burners so that no flames spread out next to pots, pans, etc.

Operating standard burners and high-power burners:

- Press the control knob, keep it pressed and turn it anti-clockwise into position ②.
- Keep the control knob pressed for about 10 seconds after the burner has ignited, until the burner gets a sufficient supply of gas.
- Adapt the burner power to the food being cooked. Set the burner knob between positions ② and ③.
- End operation: turn the control knob to position ①.

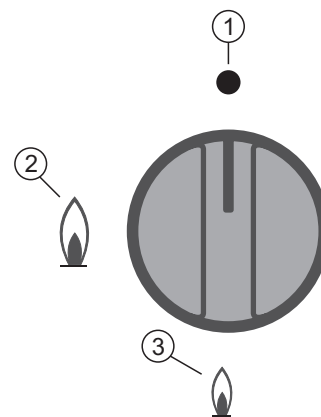

Operating a WOK burner:

- Press the control knob, keep it pressed and turn it anti-clockwise into position ②.
- Keep the control knob pressed for about 10 seconds after the burner has ignited, until it gets a sufficient supply of gas.
- Adapt the burner power to the food being cooked. Set the control knob between positions ② and ⑤.

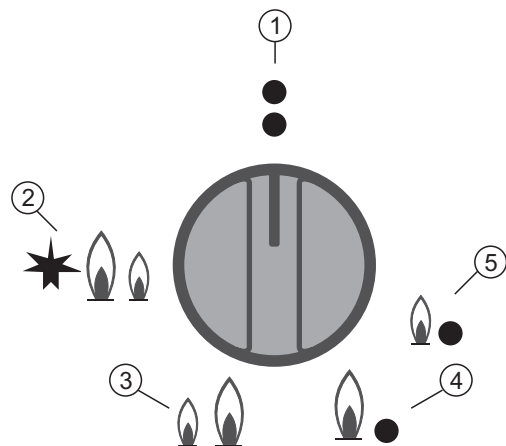

Position ② = outer burner: high flame
inner burner: high flame

Position ③ = outer burner: low flame
inner burner: high flame

Position ④ = outer burner: off
inner burner: high flame

Position ⑤ = outer burner: off
inner burner: low flame

- End operation: turn the control knob to position ①.

4 Cleaning

Keep the surface clean. Immediately remove dirt, e.g. lime, fat, protein, starch, salt and spices. Always clean the appliance after operation.

Switch off the appliance, allow it to cool down and observe the following:

- The knobs can be pulled off for cleaning purposes.
- Remove the saucepan supports and burner caps for cleaning purposes, rinse them with warm water and a little detergent and then dry.
- Clean the area under the saucepan supports. Cover the burners with tin foil and protect them against dirt and water. Use moistened sponges or cloths.
- Remove slight stains with warm water to which a little detergent has been added.
- Use a cleaning scraper on more stubborn stains (burnt food) on the glass.

5 Troubleshooting

5.1 Safety when troubleshooting



WARNING

Fatal injury caused by explosive gas

- A smell of gas means that there is a risk of explosion:
 - DO NOT ignite gas hobs or electrical switches.
 - Immediately close gas shut off valves.
 - Open windows and doors.
 - Have a gas fitter find out the cause and rectify it.

Fatal injury caused by electricity

- Have all the work on the electrical system carried out by a qualified electrician.
- Pull out the mains plug.
- After a short circuit: have a complete check of the appliance carried out by an electrician.

Serious injury caused by improper troubleshooting

- Only carry out work described in these instructions. Any other work or repairs requires extensive technical knowledge. The dealer's customer service (see the last page for the address) is responsible in this case.
- Only use original components.

5.2 Finding faults

Malfunction	Cause(s)	Measure(s)
Burner will not ignite	Slits (gas outlets) on the burner head blocked	<ul style="list-style-type: none"> → Remove the saucepan support → Take the cap off the burner head → Clean the slits on the burner head
	Mains connection interrupted	→ Check the mains connection
	Gas stop valve closed	→ Open the gas stop valve
	Burner defect	<ul style="list-style-type: none"> → Close the gas stop valve → Inform the dealer's customer service
Burner goes off after ignition	Control knob not pressed long enough	→ Keep the control knob pressed for approx. 10 seconds after ignition
Flame flickers	Slits (gas outlets) on the burner head blocked	<ul style="list-style-type: none"> → Remove the saucepan support → Take the cap off the burner head → Clean the slits on the burner head
	Burner cap does not sit properly	→ Put the burner cap on the burner properly
Burner can only be ignited when the burner is pressed for a long time	Temperature sensor bent	→ Carefully bring the temperature sensor into a vertical position
Gas escapes	Supply lines and/or connections leaking	<ul style="list-style-type: none"> → Close the gas stop valve → Inform a qualified gas fitter

6 Technical data

This section shows the technical data. The values shown serve to support orientation and may deviate slightly.

	GKS 3920.0	GWS 3911.0	GKS 6940.0	GKS 9951.0
Width x height x depth	(300 x 517 x 50) mm	(300 x 517 x 50) mm	(600 x 517 x 50) mm	(900 x 517 x 50) mm
Weight:	approx. 8.6 kg	approx. 8.6 kg	approx. 14.2 kg	approx. 21.8 kg
Standard burner [Qn (H ₂):	1 x 1.7 kW (max.)	–	2 x 1.7 kW (max.)	2 x 1.7 kW (max.)
High-power burner [Qn (H ₂):	1 x 3.8 kW (max.)	–	2 x 3.8 kW (max.)	2 x 3.8 kW (max.)
WOK burner [Qn (H ₂):	–	1 x 5.0 kW (max.)	–	1 x 5.0 kW (max.)
Power consumption (electrical):	0.8 VA (only when igniting)			
Power supply (electrical):	220 – 240 V, 50 – 60 Hz			
Gas connection:	1/2"			
Type of gas:	Hong Kong Towngas G110, 15 mbar			

7 Changing types of gas



WARNING

Danger caused by improper conversion to other types of gas

- Have only qualified gas fitters convert the appliance to another type of gas in accordance with local regulations.
- The type of gas and the inlet pressure must comply with the appliance gas setting; see the marking (back of the appliance).
- Only use Küppersbusch injector sets (scope of delivery).
- Before changing:
 - Close the gas stop valve.
 - Pull out the mains plug.
- After changing:
 - Make changes permanently recognisable on the nameplate by sticking the labels for the injector sets (scope of delivery) on the bottom of the appliance.
 - Check to ensure that there are no leaks on the gas connections.
 - Test the appliance for correct functioning.
 - The sealing must be renewed when the appliance has been converted to another type of gas or when the gas pressure has been changed.

7.1 Injector specification



WARNING

Damage to health resulting from the use of unsuitable injectors

The use of injectors larger than those authorised for the gas/inlet pressure will damage the health of the user (emission of CO) and of the appliance.

- Only use Küppersbusch injector sets (scope of delivery). The values in the following table are stamped on the injector heads!



Injector specification full flame injector / low setting injector

Type of gas	Individual burner		WOK burner	
	High-power burner	Standard burner	Inside	Outside
Liquefied gas butane/propane G30 (28 – 30/37 mbar)	98/25	65/25	50/23	72/45

7.2 Changing gas used by high-capacity and standard burners

Replacing the injectors:



WARNING Danger of electric shock!
Pull out the mains plug.
Discontinue the supply of gas.

CAUTION
Hot surfaces.

- Remove the saucepan support ①.
- Take off the burner cap ②.
- Remove the attachment for the burner cap ③.
- Screw out the main adjusting injector with a socket spanner.
- Screw in the new main adjusting injector until it stops. Observe the injector specification.

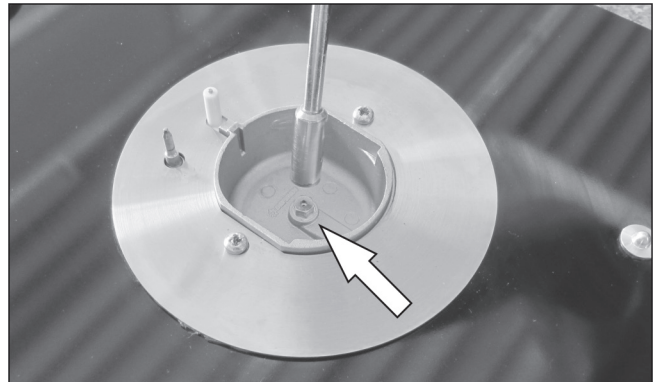
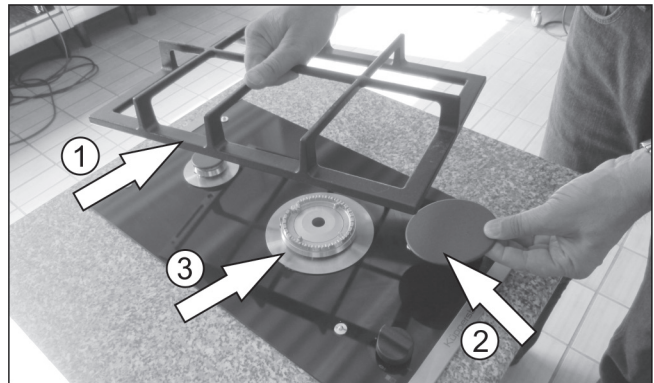

Removing the gas hob:

Example: Appliance type GWS 3911.0

- Push against the gas hob from below and remove it.
- Remove all the screw from the burner flange.

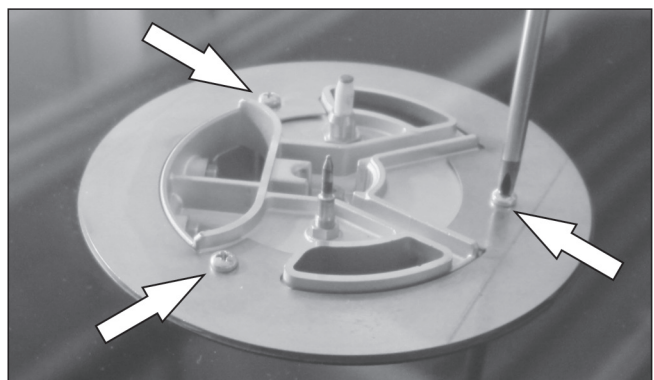
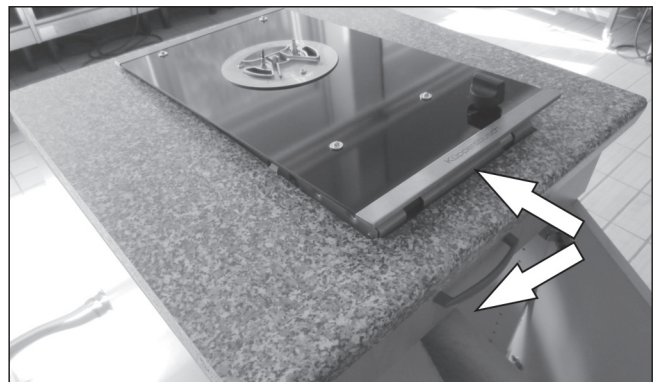

Instructions for use - Gas hobs

Changing types of gas

- Screw the glass ceramic top off the hob cavity.

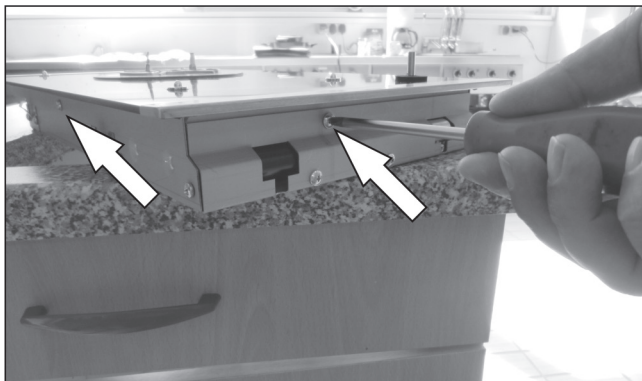

- Remove the glass ceramic top.

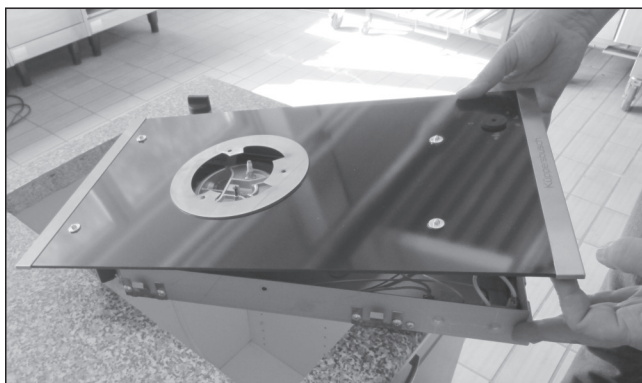

Dismantling the gas tap:

- Remove the rubber cap ①.
- Remove the holder ② to the side.
- Remove component part ③.

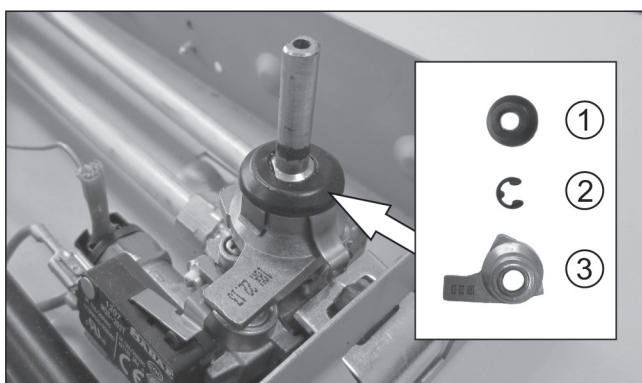

- Loosen the screws on the top part of the gas tap.

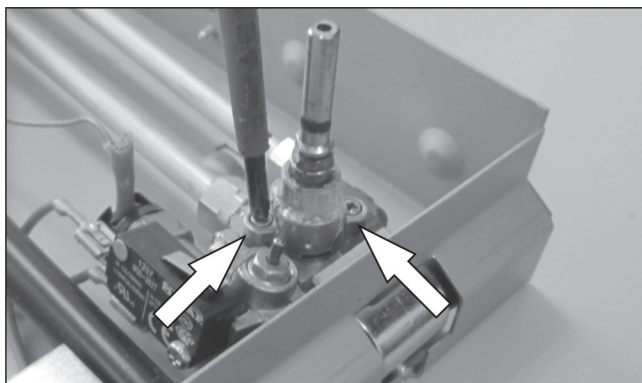

- Remove the top part of the gas tap.

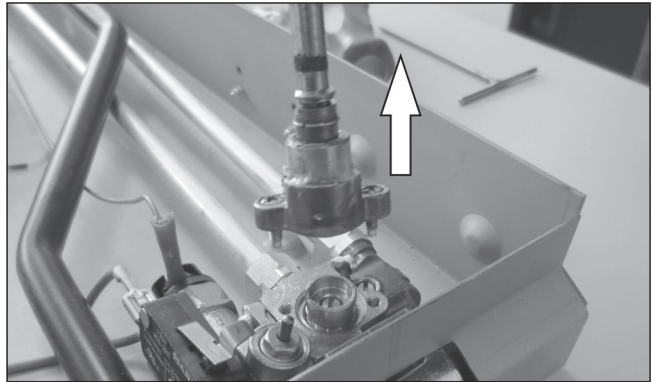

- Screw the low setting injector ① out and remove it with pointed pliers ②.
- Screw in the new low setting injector until it stops. Observe the injector specification.

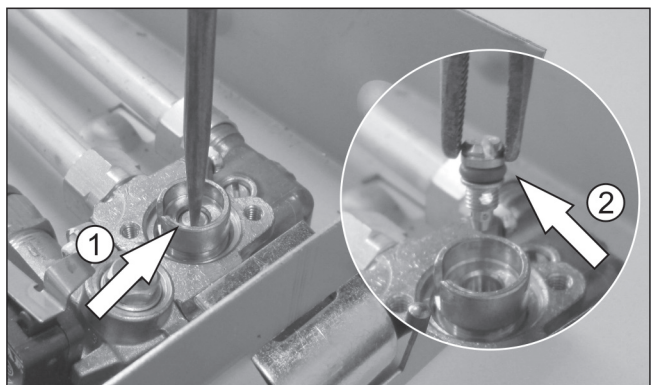

- Insert the top part of the gas tap ①, making sure that the peg (underside of the top part of the gas tap) is guided into the groove (injector holder).

If the positions no longer correspond: carefully align the groove.

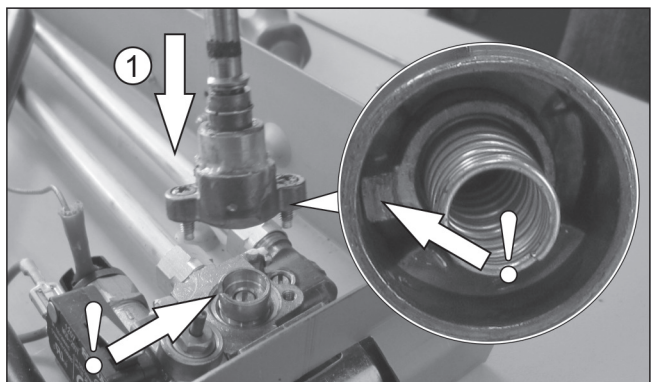

- Screw the top part of the gas tap tight.

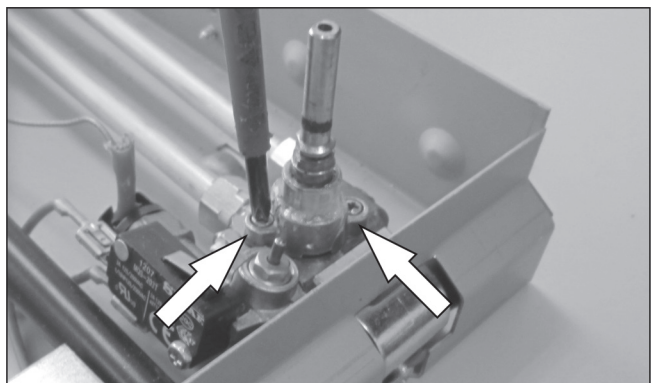

Instructions for use - Gas hobs

Changing types of gas

- Replace component parts ① to ③.
- Place the glass ceramic top into the hob cavity and screw it on.
- Screw the burner flange tight.
- Seal the appliance.

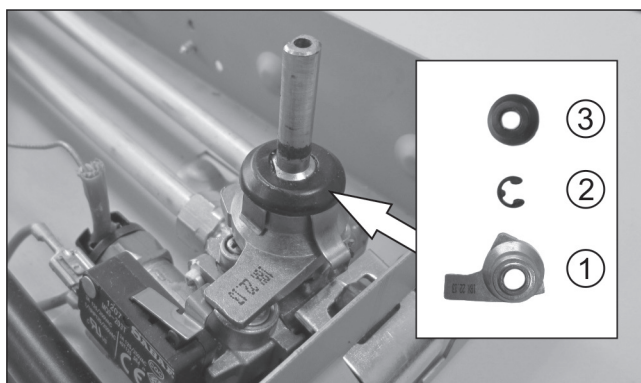

- Stick the labels for the injector sets used (scope of delivery) onto the back of the appliance above the previous label.

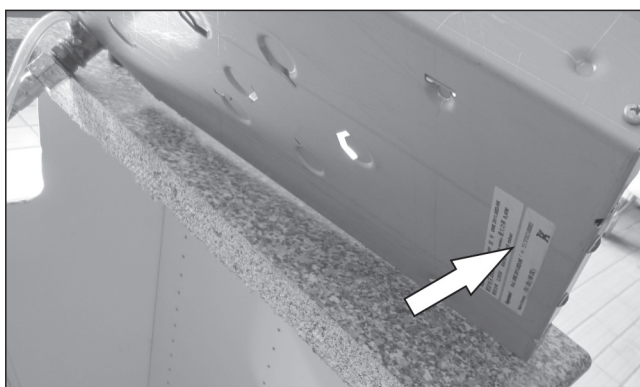

- Put the gas hob into the worktop.
- Insert the attachment for the burner cap.
- Install the burner caps.
- Put the saucepan supports into position.
- Restore the gas supply.
- Restore the power supply.

- Ignite the burner.
- Use a screwdriver to set the low setting injector so that the flame does not flicker even at the lowest setting.
- Put the control knob on again and turn it quickly between the highest and the lowest setting several times. Readjust if the flame goes off.



7.3 Changing the gas used by the WOK burner

Replacing the injectors:



WARNING

Danger of electric shock! Pull out the mains plug.
Discontinue the supply of gas.

CAUTION

Hot surfaces.

- Pull the control knob off by pulling it upwards.
- Remove the saucepan support.

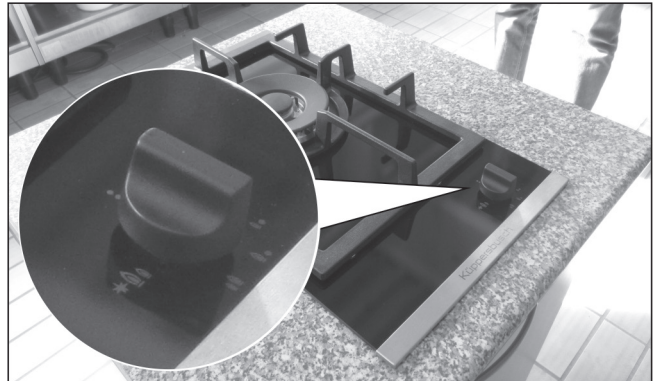

- Remove the burner cap and the attachment.



- Screw out the main adjusting injector with a socket spanner.
- Screw in the new main adjusting injector until it stops. Observe the injector specification.

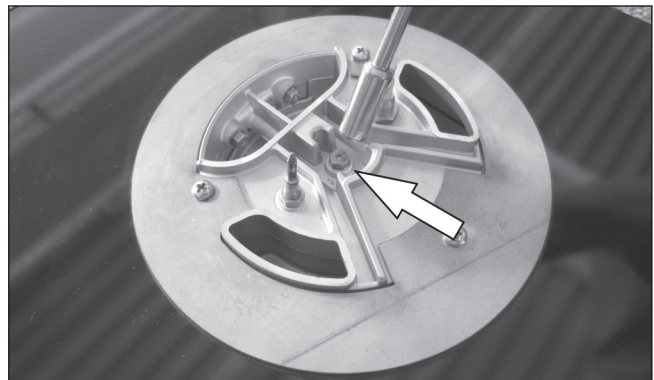

Instructions for use - Gas hobs

Changing types of gas

- Remove both main adjusting injectors with an open-jawed spanner (size 7).
- Screw in the new main adjusting injectors until they stop. Observe the injector specification.

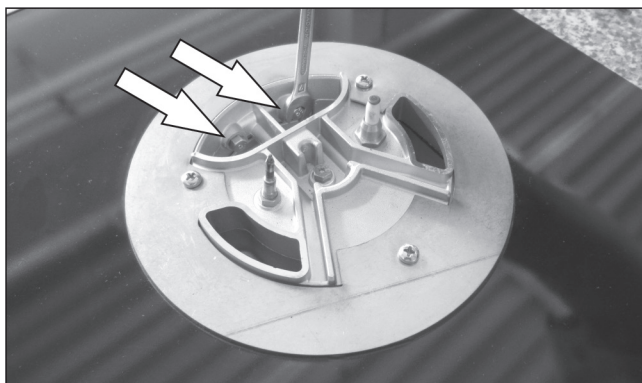

Removing the gas hob:

Example: Appliance type GWS 3911.0

- Push against the gas hob from below and remove it.

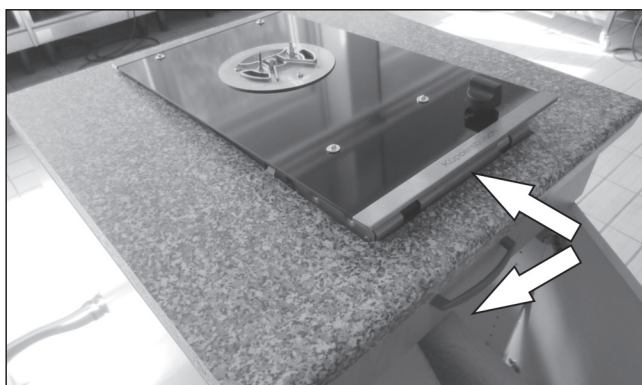

- Remove all the screw from the burner flange.

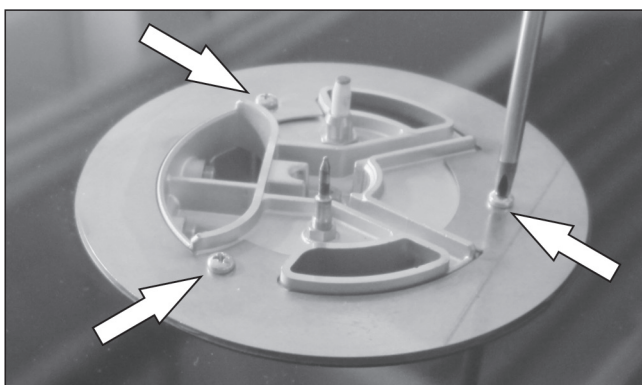

- Screw the glass ceramic top off the hob cavity.

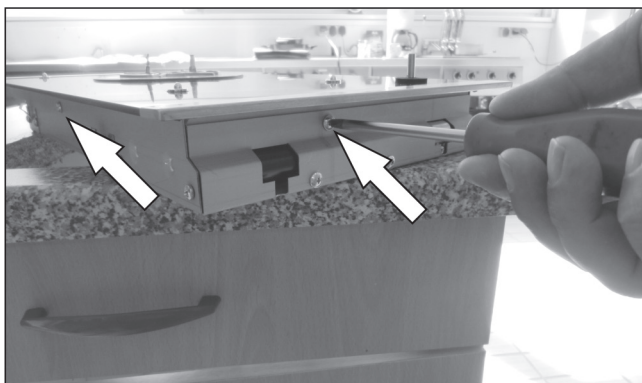

- Remove the glass ceramic top.

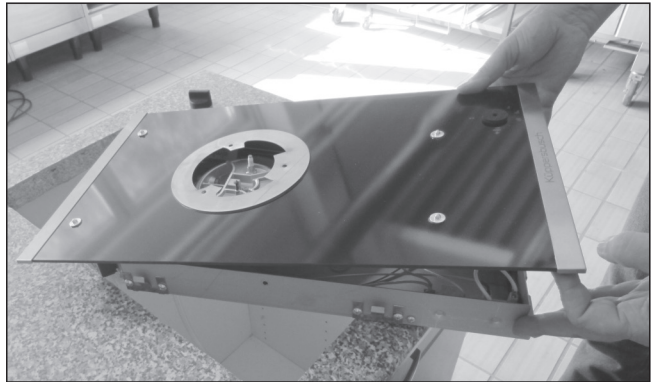

- Screw the low setting injector out with a screwdriver and remove it with pointed pliers.
- Screw in the new low setting injector until it stops. Observe the injector specification.

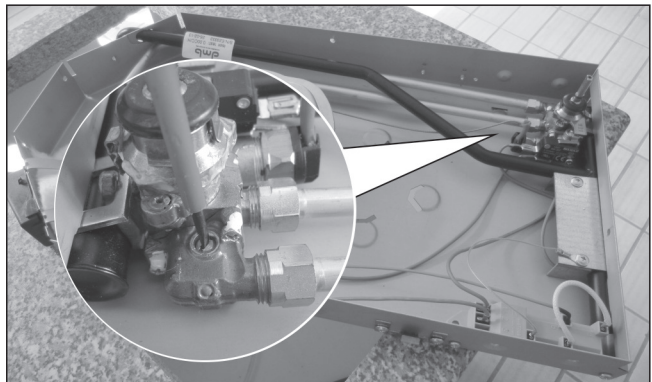

Dismantling the gas tap:

- Remove the rubber cap ①.
- Remove the holder ② to the side.
- Remove component parts ③ and ④.

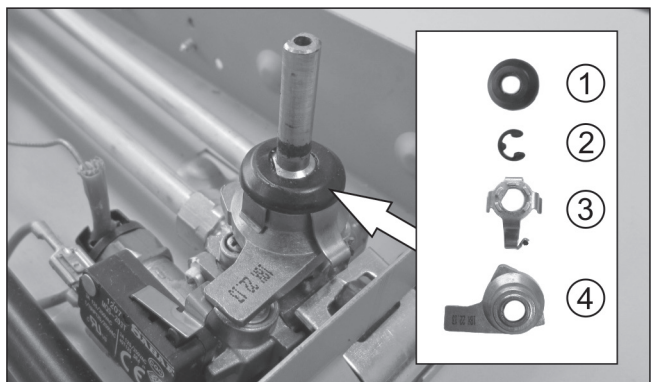

- Loosen the screws on the top part of the gas tap.

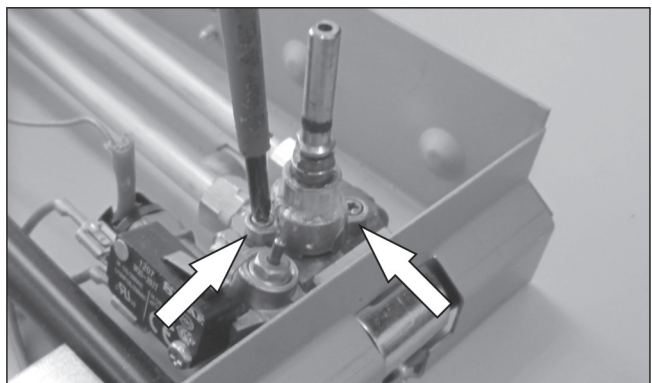

Instructions for use - Gas hobs

Changing types of gas

→ Remove the top part of the gas tap.

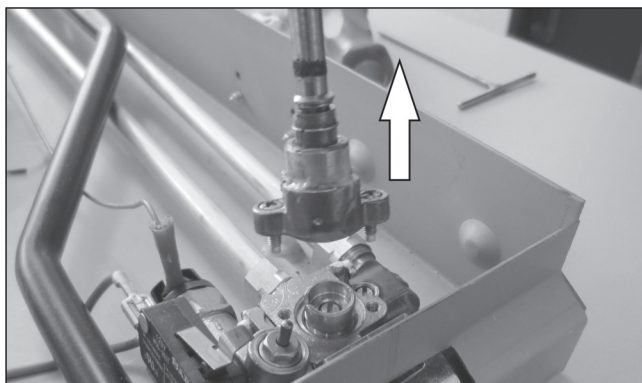

→ Screw the low setting injector ① out and remove it with pointed pliers ②.

→ Screw in the new low setting injector until it stops. Observe the injector specification.

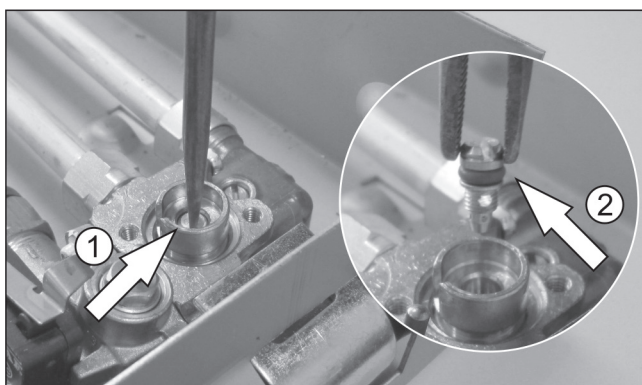

→ Insert the top part of the gas tap ①, making sure that the peg (underside of the top part of the gas tap) is guided into the groove (injector holder).

If the positions no longer correspond: carefully align the groove.

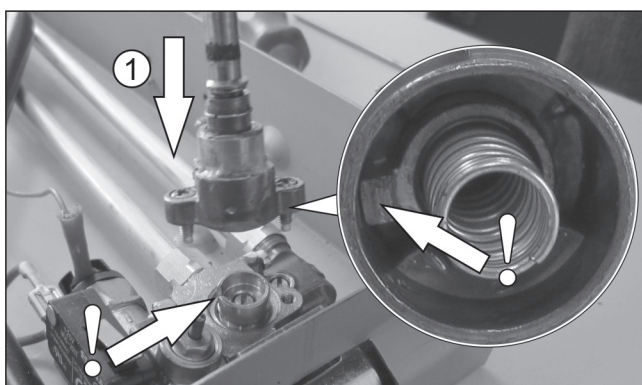

→ Screw the top part of the gas tap tight.

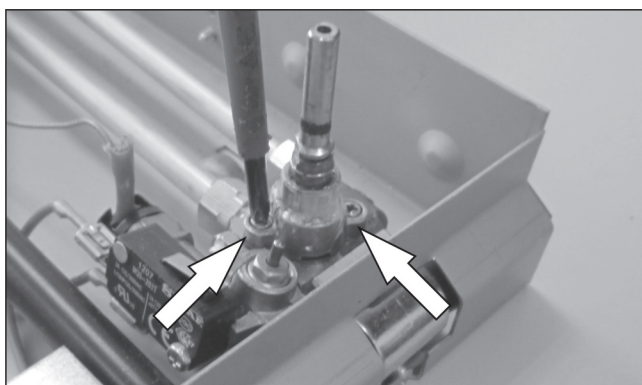

- Replace component parts ① to ④.
- Place the glass ceramic top into the hob cavity and screw it on.
- Screw the burner flange tight.
- Seal the appliance.

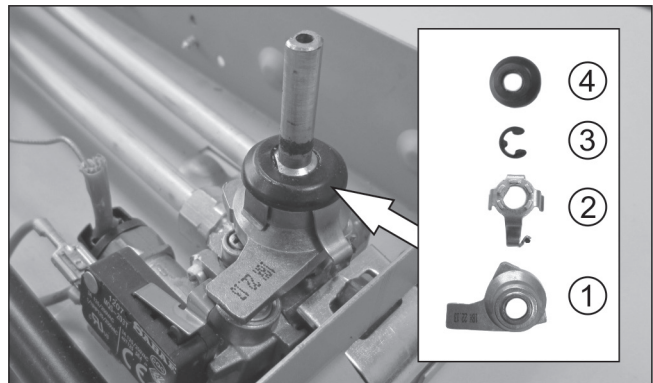

- Stick the labels for the injector sets used (scope of delivery) onto the back of the appliance above the previous label.

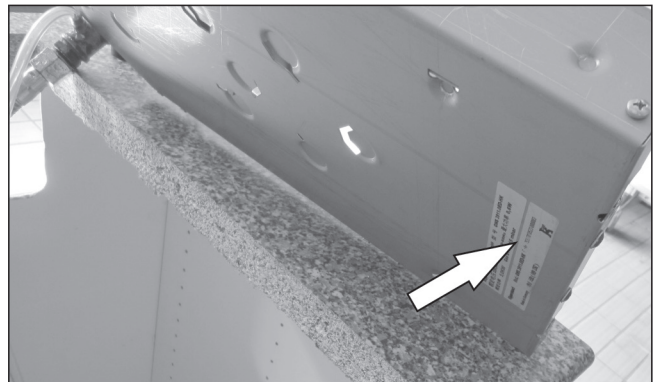

- Put the gas hob into the worktop.
- Insert the attachment for the burner cap.
- Install the burner caps.
- Put the saucepan supports into position.
- Restore the gas supply.
- Restore the power supply.

- Ignite the burner.
- Use a screwdriver to set the low setting injector so that the flame does not flicker even at the lowest setting.
- Put the control knob on again and turn it quickly between the highest and the lowest setting several times. Readjust if the flame goes off.



Küppersbusch Hausgeräte GmbH
Postfach 10 01 32, D-45801 Gelsenkirchen (Germany)
Küppersbuschstr. 16, D-45883 Gelsenkirchen (Germany)
Telephone: +49 209 401-0, fax: +49 209 401-303
www.kueppersbusch.de

Shun Hing Electric Works & Engineering Co., Ltd.
Room 601, East Ocean Centre, 6/F., 98 Granville Road
Tsimshatsui East, Kowloon
Hong Kong
www.shunhinggroup.com