

VACUUM DRAWER

CSV 6800.0/ZV8020/DK1002

Küppersbusch
FÜR KÜCHEN MIT STIL

Professional+

Features:

- Ideal complement for a 45 cm high appliance for a 59 cm high built-in niche
- Glass front (see optional accessories) or existing furniture mountable
- Electronic control with touch control sensors
- Electronic display in red
- Stainless steel vacuum chamber
- 3 m³/h vacuum power of the pump
- Max. bag dimensions 305 mm
- Telescopic rails



with black glass front and stainless steel design kit



Technical data:

- Electrical connection : 0.4 kW
- Appliance dimensions : approx. W595 x H140 x D550 mm
- Niche dimensions : W x H x D approx. 560 x 595 x 550 mm
incl. an appliance of 45 cm height
- Inner dimensions : 310 x 330 x 65/85 mm

Standard accessories:

- 25 vacuum bags 200 x 300 mm
- 25 vacuum bags 250 x 300 mm
- 1 reduction inlay
- 1 vacuum jet

Optional accessories:

- Black glass front Acc. no. ZC 8020
- White glass front Acc. no. ZC 8022
- Design kit Stainless Steel Acc. no. DK 1002
- Design kit Black Chrome Acc. no. DK 2002
- Design kit Silver Chrome Acc. no. DK 3002
- Design kit Gold Acc. no. DK 4002
- Design kit Black Velvet Acc. no. DK 5002
- Design kit Copper Acc. no. DK 7002
- Design kit Hot Chili Acc. no. DK 8002

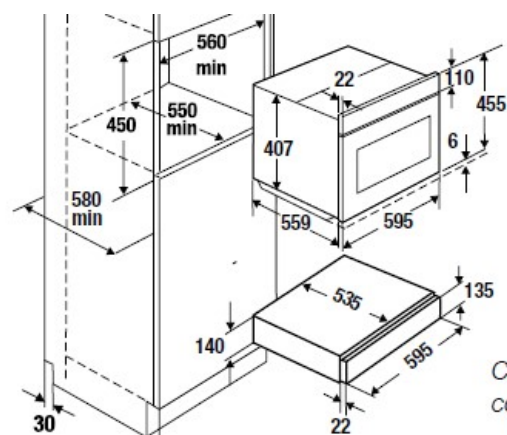

CSV 6800.0 with 45 cm compact appliance



信興電工工程有限公司

Shun Hing Electric Works & Engineering Co., Ltd.